

Surgical Technique

 smith&nephew

TRIGEN[◇]
META-NAIL[◇]

Tibial Nail System



TRIGEN[◇] META-NAIL[◇] Tibial Nail System

Surgical Technique

Table of Contents

Indications	2
Implant Specifications	3
Surgical Technique	
Patient Positioning	4
Incision and Entry Point	6
Entry Portal Acquisition	7
Entry Portal	8
Alternative Technique: Entry Portal	8
Fracture Reduction	10
Reducer Removal	10
Implant Measurement	11
Unreamed Technique.....	12
Reamed Technique	13
Nail Assembly	15
Nail Insertion	16
Check Nail Depth.....	17
Locking Screw Measurement	19
Locking Screw Insertion.....	19
Proximal Locking: Static	20
Proximal Locking: Dynamic	20
Proximal Locking: Compression	21
Distal Locking.....	21
Blocking Screw Insertion Technique	
Incision & Entry Point.....	23
Entry Portal Acquisition	23
AP Blocking Screw Insertion	24
ML Blocking Screw Insertion	25
Blocking Screw Insertion With Reducer.....	26
Stability Blocking Screw Insertion	27
Nail Cap Insertion	28
Nail Extraction	
Standard Technique.....	30
Percutaneous Technique	30
Guide Rod Jamming Technique.....	31
Catalog Information	32

Nota Bene

The technique description herein is made available to the healthcare professional to illustrate the authors' suggested treatment for the uncomplicated procedure. In the final analysis, the preferred treatment is that which addresses the needs of the patient.

Indications

The TRIGEN® META-NAIL® Tibial Nail is indicated for fractures of the proximal and distal third of the tibia, including the shaft, stable and unstable fractures, non-unions, mal-unions, and for the prophylactic nailing of impending pathological fractures.



TRIGEN[◇] META-NAIL[◇] Tibial Nail Specifications



ML View

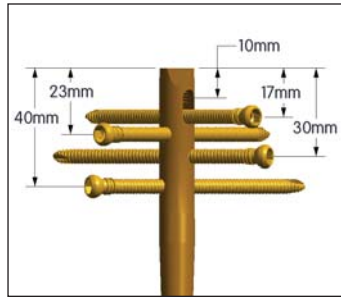

Driving End of Nail (All Knee and Distal Tibial)

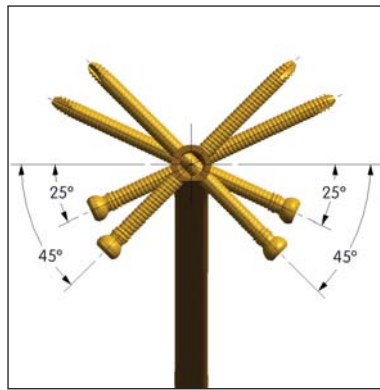

Top View of Nail

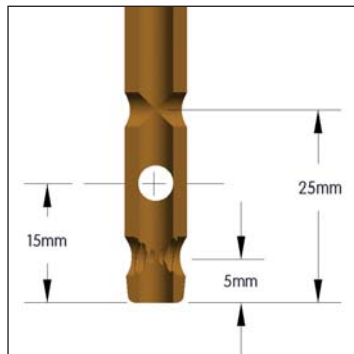

Non-driving End of Nail (AP view)

NOTE: These views are not to scale and should be used as a pictorial representation only.

Specifications	TRIGEN META-NAIL (8.5mm)	TRIGEN META-NAIL
Material	Ti6AL4V	Ti6AL4V
Diameter	8.5mm	10, 11.5 & 13mm
Lengths	16-50cm*	16-50cm*
Nail Color	Grey	gold
Cross Section	Round	Round
Proximal Diameter (driving end)	12mm	12mm (10, 11.5 dia.) 13mm (13 dia.)
Distal Diameter (non-driving end)	8.5mm	10, 11.5 & 13mm
Smallest Thru Diameter	4.8mm	5.0mm
Wall Thickness	1.9mm	2.3mm (10) 3.0mm (11.5) 2.3mm (13)
Guide Bolt Thread	5/16-24 UNF	5/16-24 UNF
Screw Diameter	4.5mm	5.0mm
Screw Color	Grey	gold
Major Diameter	4.5mm	5.0mm
Minor Diameter (core)	4.0mm	4.3mm
Screw Lengths	25-65mm	25-110mm
Hex Size	4.7mm	4.7mm
Alternative Hex Drivers	RT Femoral & Recon 7.0mm Cannulated Screw PERI-LOC [®] Locking Screw	RT Femoral & Recon 7.0mm Cannulated Screw PERI-LOC [®] 4.7mm Hex Driver, PROFIX [®] 4.7mm Hex Driver
Alternative Modes	No	No
Proximal Locking (Driving End)		
Static Lock Locations/Orientations	17mm/45° Screw Locked w/META-NAIL Cap 23mm/45° Threaded w/bushing 30mm/25° Threaded 40mm/25° Threaded	
Static Locking Hole Dimensions	Threaded 4.3mm minor dia. Threaded 4.7mm major dia.	Threaded 4.5mm minor dia. Threaded 5.3mm major dia.
Compression/Dynamic Slot Location	10mm	10mm
Compression/Dynamic Slot Diameter/Length	4.7mm/7mm	5.3mm/7mm
Degree of Proximal Bend (Herzog)	10°	10°
Proximal Bend Location	27mm	27mm
Distal Locking (Non-Driving End)		
Static Lock Locations/Orientations	25mm/ML 15mm/AP 5mm/ML (Threaded)	25mm/ML 15mm/AP 5mm/ML (Threaded)
Static Locking Hole Dimensions	4.7mm**	5.3mm**
Degree of Distal Bend	2°	2°
Distal Bend Location	60mm	60mm

*Set does not include all sizes; Outlier sizes may be special order only.
**Most distal hole threaded.

Surgical Technique

Patient Positioning

Position the patient supine on a radiolucent table with the unaffected limb extended away from the affected limb. Alternatively, a fracture table may be used with a pin inserted through the calcaneus to place the leg in traction. Flex the affected limb 80-90° and check for length and rotation by comparison to the unaffected limb.

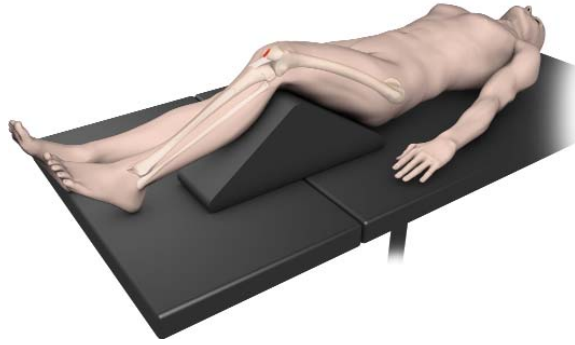

Use a bolster or radiolucent triangle to maintain limb position. Rotate the C-Arm to ensure optimal AP and lateral visualization of the entire tibia. A distraction device may also be applied to obtain and/or maintain traction.



Instruments for Opening the Proximal Tibia



3.2mm Tip Threaded Guide Wire
Cat. No. 7163-1690



Mini Connector
Cat. No. 7163-1186



12.5mm Entry Reamer
Cat. No. 7163-1116



T-Handle
Cat. No. 7167-4076



Honeycomb
Cat. No. 7167-4075

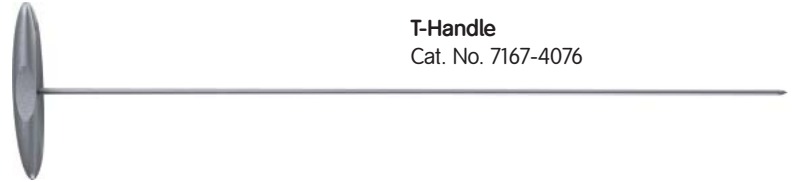

3.2mm T-Handle Trocar
Cat. No. 7167-4074



Entry Portal Tube
Cat. No. 7167-4060



Entry Portal Handle
Cat. No. 7167-4092



Cannulated Awl
Cat. No. 7167-4000

Surgical Technique (continued)

Incision and Entry Point

Assemble the Honeycomb (7167-4075), Entry Handle (7167-4092) and Entry Tube (7167-4060). The pieces will lock in place securely at either 0° or 180°.

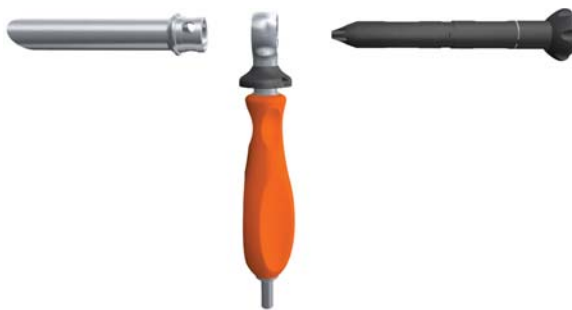

A 2cm incision is made in-line with the intramedullary canal. This may be patellar splitting, medial or lateral parapatellar in its orientation.



The entry point is located just medial to the lateral tibial eminence in the AP view, and in-line with the anterior cortex and intramedullary canal in the lateral.

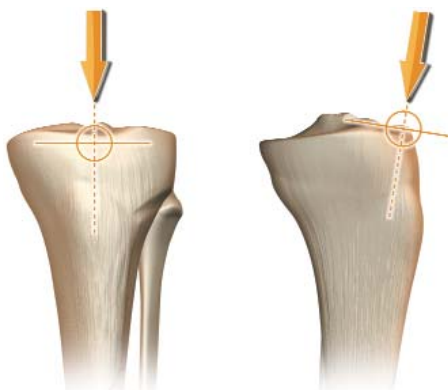

Entry Portal Acquisition

Attach a 3.2mm Tip Threaded Guide Wire (7163-1690) to the drill via the Mini Connector (7163-1186) and insert into the proximal tibia to a depth of 4-6cm. The Entry Portal instrumentation serves as a soft tissue protector.

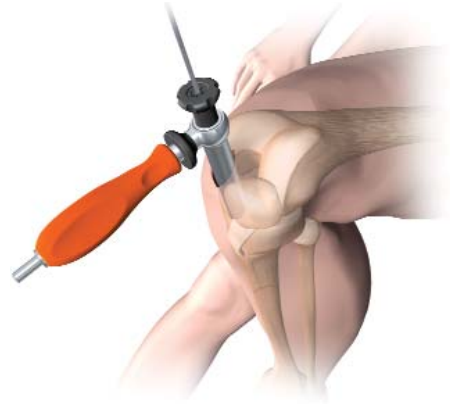

In the instance of suboptimal Guide Wire insertion, rotate the Honeycomb within the Entry Tube to the desired location and insert another 3.2mm Tip Threaded Guide Wire. Avoid over-insertion of the Guide Wire as this can establish a false trajectory and lead to fracture malalignment.

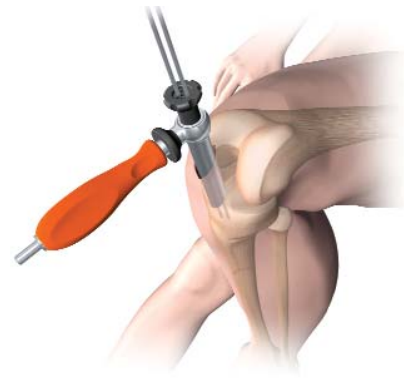

Surgical Technique (continued)

Entry Portal

After definitive Guide Wire placement, remove the Honeycomb from the Entry Tube along with any additionally inserted Guide Wires and attach the 12.5mm Entry Reamer (7163-1116) to power. Advance over the Guide Wire through the Entry Tube to a depth of 4-6cm. Maintain alignment so as to avoid penetration of the posterior cortex.



Check position via radiographic imaging and then remove the 12.5mm Entry Reamer and 3.2mm Tip Threaded Guide Wire.

Alternative Technique: Entry Portal

Attach the T-Handle (7167-4076) to the Cannulated Awl (7167-4000) and insert into the proximal tibia to a depth of 4-6cm. Introduce the 3.2mm T-Handle Trocar (7167-4074) into the back of the assembly prior to insertion in order to prevent awl slippage and accumulation of cortical bone within the cannulation.



Cannulated Awl
with T-Handle

3.2mm T-Handle
Trocar

Instruments for Fracture Reduction & Reaming



Entry Portal Tube
Cat. No. 7167-4060



Entry Portal Handle
Cat. No. 7167-4092



Gripper
Cat. No. 7167-4080



Ruler
Cat. No. 7167-4079



T-Handle
Cat. No. 7167-4076



Reamer Heads
Cat. No. 7111-8231-8246



Obturator
Cat. No. 7167-4078



Flexible Reamer Shaft
Cat. No. 7111-8200



Reducer
Cat. No. 7167-4077



3.0mm x 1000mm Ball Tip Guide Rod
Cat. No. 7163-1626

Surgical Technique (continued)

Fracture Reduction

Insert the back end of the 3.0mm Ball Tip Guide Rod (7163-1626) into the front of the Gripper (7167-4080) and gently close the trigger-grip. Connect the Reducer and Reducer Connector (7167-4077) so that the words “Slot Orientation” are in line with the opening at the tip. Complete the assembly by connecting it to the T-Handle.



Note: If blocking screws are desired at this point in the procedure, refer to the blocking screw technique section (pp 22-28).



Advance the Reducer into the intramedullary canal and use the curved tip to direct the 3.0mm Ball Tip Guide Rod past the fracture into the region of the distal epiphyseal scar. The Guide Rod should be center-center in the AP and lateral views.



Reducer Removal

Once the Guide Rod is at the desired depth, detach the Gripper and remove the Reducer from the tibial canal. Slide the Obturator (7167-4078) into the back of the T-Handle during extraction in order to maintain Guide Rod position within the canal.

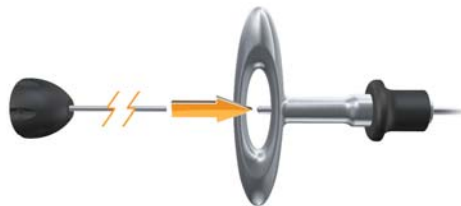

Implant Measurement

After Reducer removal, re-confirm Guide Rod placement within the distal tibia and slide the Ruler (7167-4079) over the Guide Rod to the desired depth. The metal tip of the Ruler denotes the driving end of the META-NAIL[®] Tibial Nail.



Confirm Guide Rod position in the window at the opposite end of the Ruler as shown in order to ensure accurate implant measurement. Push down on the top of Ruler until contact is made with the 3.0mm Ball Tip Guide Rod. Implant length is read from the exposed calibrations at the end of the Ruler.



Note: Confirm fracture reduction so as not to underestimate correct implant length. Reference the fibula for accurate fracture distraction or compression.

Note: Confirm that the Ruler opens easily. Adjust the thumb-wheel connection at the end to allow for free movement.

Surgical Technique (continued)

Unreamed Technique

Radiographic templating is used to determine nail size. The appropriate diameter implant will provide translational fill within the isthmus of the intramedullary canal. Generally, selection of a nail approximately 1-1.5mm less than the narrowest canal measurement on the Lateral radiograph assists in avoiding implant incarceration during insertion.

Note: The 7.6mm diameter of the Reducer provides an initial “sound” for determining canal width in small diameter tibias.

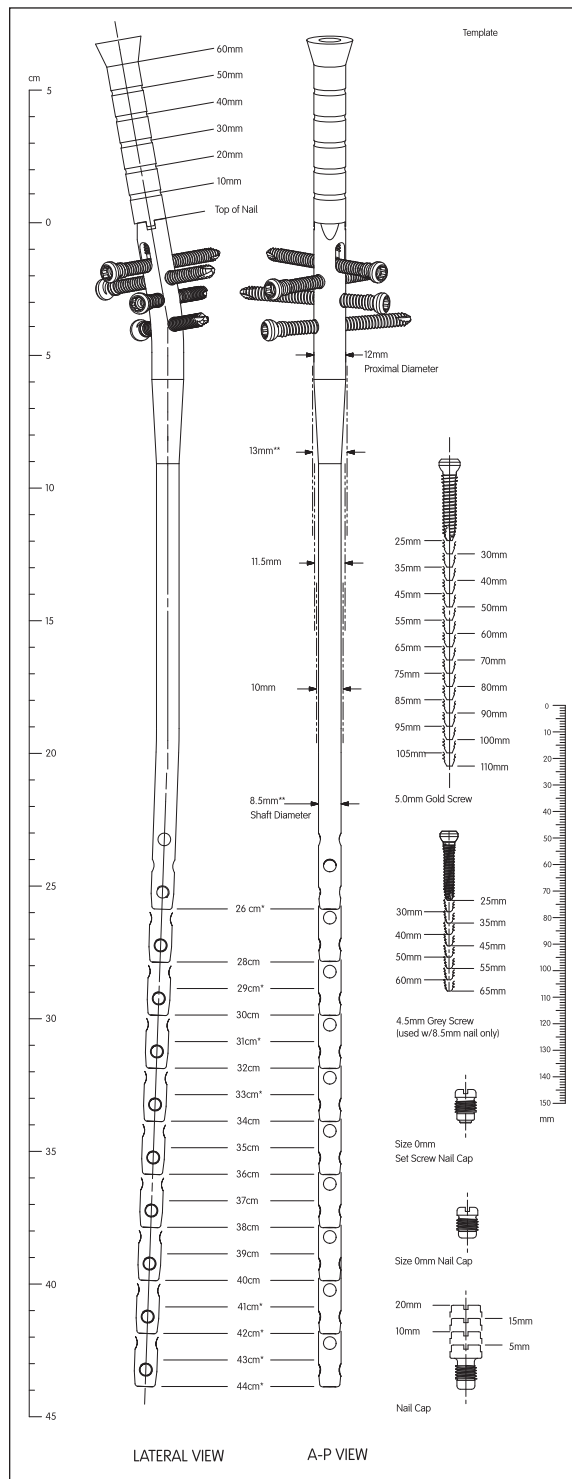

TRIGEN® META-NAIL® Tibial Nail Radiographic Template
Cat. No. 7118-0810

Reamed Technique

Radiographic templating and intra-operative measurement will determine nail size. Beginning with the 9.0mm Front Cutting Reamer Head (7111-8231) and Flexible Reamer Shaft (7111-8200), ream the intramedullary canal sequentially in half millimeter increments to a size 1-1.5mm larger than the selected nail size.

Ensure Guide Rod placement during reaming by inserting the Obturator into the back of the Reamer unit during retraction. Continue to confirm Guide Rod placement in the distal tibia throughout reaming. Periodically move the reamer back and forth in the canal to clear debris from the cutting flutes.



Surgical Technique (continued)

Instruments for Nail Assembly & Insertion



Guide Bolt Wrench
Cat. No. 7163-1140



META-NAIL° Anterior Drop
Cat. No. 7165-4501



META-NAIL Drill Guide
Cat. No. 7165-4502



META-NAIL Extension Drill Guide
Cat. No. 7165-4503



9.0mm Drill Sleeve
Cat. No. 7163-1152



4.0mm Drill Sleeve
Cat. No. 7167-4083



Extension Guide Bolt
Cat. No. 7165-4505



4.0mm Long Pilot Drill*
Cat. No. 7163-1110



Short Impactor
Cat. No. 7165-4521



Guide Bolt Long
Cat. No. 7165-4506



Impactor
Cat. No. 7167-4081



T-Handle
Cat. No. 7167-4076



Slotted Hammer
Cat. No. 7167-4082

* 4.0mm Long Pilot Drill (7163-1110) is interchangeable with 4.0mm AO Long Drill (7163-1121)

Nail Assembly

Attach the META-NAIL® Drill Guide (7165-4502) to the nail with the Guide Bolt Long (7165-4506) and tighten with the Guide Bolt Wrench (7163-1140) and T-Handle. The nail is correctly aligned when:

1. The line on the insertion barrel matches the line of the nail
2. The “A” on the nail matches the “A” on the insertion barrel
3. The apex of the nail's proximal Herzog Bend faces posterior and the Drill Guide is oriented anterior

The bevel on the front of the nail marks the connection to the Drill Guide and can be seen in the lateral view as a means for determining proximal insertion depth.



Note: It is recommended to use the standard Drill Guide and Guide Bolt Long for compression or dynamic locking as the longer insertion barrel facilitates countersinking of the nail.

Note: The assembly and insertion of the grey 8.5mm diameter META-NAIL Tibial Nail follows the same technique as the 10mm, 11.5mm and 13mm diameter nails.

Attach the Anterior Drop (7165-4501) to the Drill Guide and verify targeting accuracy by inserting a gold 9.0mm Drill Sleeve (7163-1152) and silver 4.0mm Drill Sleeve (7167-4083) into the Drop and passing a 4.0mm Long Pilot Drill (7163-1110)* through the assembly. An incorrectly attached nail will not target.



* 4.0mm Long Pilot Drill (7163-1110) is interchangeable with 4.0mm AO Long Drill (7163-1121)

Surgical Technique (continued)

Nail Insertion

Remove the Anterior Drop and attach the Impactor (7167-4081) to the Drill Guide. Orient the Drill Guide assembly in the AP position and advance the nail over the Guide Rod by light blows from the Slotted Hammer (7167-4082) to the desired depth.

Additional reaming of the intramedullary canal may be indicated if excessive force is required to insert the nail.



Verify fracture reduction as the nail crosses the fracture site paying close attention to rotation, length, alignment, distraction and/or shortening. Check final nail position in both the AP and lateral views for correct alignment.

For proximal interlocking with the leg in extension use the Extension Drill Guide (7165-4503) and Extension Guide Bolt (7165-4505). The long insertion barrel of the standard Drill Guide may impinge upon the distal femoral condyles and prevent nail interlocking with the tibia in full extension.

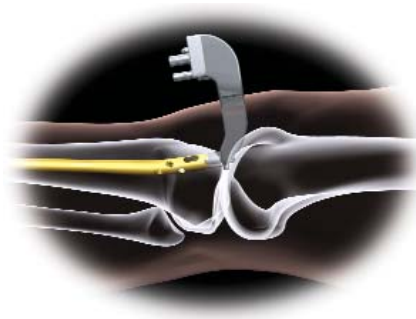

Check Nail Depth

Proximal

In the lateral view, confirm nail position by observing the notch present at the nail/Drill Guide junction. Each gauge on the insertion barrel represents a 10mm depth interval. If compression or dynamic locking is desired, it is recommended to countersink the nail approximately 10mm in order to avoid implant prominence.



Distal

In the AP and lateral views, confirm that the nail has been inserted to the desired depth. Distal third tibia fractures require at least three locking screws to maintain stability, so optimal insertion depth is essential. Remove the Guide Rod once the nail has been fully seated and attach the Anterior Drop.



Note: Following nail insertion, confirm that the nail and Drill Guide are securely connected as hammering can loosen the Guide Bolt.

Surgical Technique (continued)

Instruments for Standard, Dynamic & Compression Locking



Screw Length Sleeve
Cat. No. 7167-4085



Nail Cap Set Screw
Cat. No. 7165-6000



META-NAIL® Anterior Drop
Cat. No. 7165-4501



Medium Hexdriver
Cat. No. 7163-1066



Mini Connector
Cat. No. 7163-1186



4.0mm Drill Sleeve
Cat. No. 7167-4083



Screwdriver Release
Cat. No. 7167-4084



9.0mm Drill Sleeve
Cat. No. 7163-1152



Disposable Compression Driver
Cat. No. 7165-4517



4.0mm Long Pilot Drill*
Cat. No. 7163-1110



4.0mm Short Drill**
Cat. No. 7163-1117



T-Handle
Cat. No. 7167-4076



Screw Depth Gauge
Cat. No. 7163-1189

* 4.0mm Long Pilot Drill (7163-1110) is interchangeable with 4.0mm AO Long Drill (7163-1121)

** 4.0mm Short Drill (7163-1117) is interchangeable with 4.0mm AO Short Drill (7163-1123)

Locking Screw Measurement

There are three (3) methods:

1. Gold 9.0mm Drill Sleeve, silver 4.0mm Drill Sleeve and 4.0mm Long Pilot Drill*
2. Screw Depth Gauge (7163-1189)
3. Screw Length Sleeve (7167-4085) and 4.0mm Short Drill (7163-1117)**

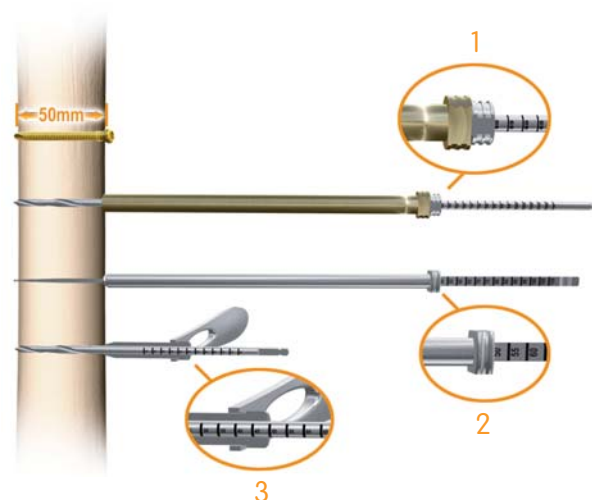

Locking Screw Insertion

Proximal locking options include three (3) statically locked threaded holes and one (1) slot that allows for both fracture compression and/or dynamization. These are targeted through the orange and blue color-coded holes on the Anterior Drop.

Distal locking options include three (3) statically locked holes, two (2) ML and one (1) AP. The most distal ML hole is threaded for additional stability.

Gold 5.0mm locking screws are compatible with 10mm, 11.5mm and 13mm diameter nails and grey 4.5mm locking screws with 8.5mm diameter nails.



Note: Do not use the 4.0mm Short Step Drill (7164-1123) when drilling for a grey 4.5mm locking screw. Its diameter transitions from 4.0mm to 4.7mm and will drill too large a hole in the near cortex. This may compromise locking screw purchase.

* 4.0mm Long Pilot Drill (7163-1110) is interchangeable with 4.0mm AO Long Drill (7163-1121)

** 4.0mm Short Drill (7163-1117) is interchangeable with 4.0mm AO Short Drill (7163-1123)

Surgical Technique (continued)

Proximal Locking: Static

Make a small incision at the site of screw entry and insert the gold 9.0mm Drill Sleeve and silver 4.0mm Drill Sleeve through the static slot on the Anterior Drop down to bone. Drill both cortices with the 4.0mm Long Pilot Drill*.



Measure for screw length using either the calibrations on the 4.0mm Long Pilot Drill* or by removing the 4.0mm Drill Sleeve and using the Screw Depth Gauge. Attach the appropriate length screw to the end of the Medium Hexdriver (7163-1066) and insert through the gold 9.0mm Drill Sleeve on power until the laser etched ring on the Hexdriver reaches the back of the Drill Sleeve. Attach the T-Handle to the Hexdriver and tighten the screw by hand.

Proximal Locking: Dynamic

With the nail countersunk approximately 10mm, make a small incision at the site of screw entry and insert the gold 9.0mm Drill Sleeve and silver 4.0mm Drill Sleeve through the dynamic slot on the Anterior Drop down to bone. Drill both cortices with the 4.0mm Long Pilot Drill*. Screw measurement and insertion follows the previously described technique.



* 4.0mm Long Pilot Drill (7163-1110) is interchangeable with 4.0mm AO Long Drill (7163-1121)

Proximal Locking: Compression

There are two (2) methods:

1. With the nail countersunk approximately 10mm, lock the nail distally first (see below) to ensure effective compression and insert a screw through the proximal dynamic slot as previously described. Remove the gold 9.0mm Drill Sleeve and Medium Hexdriver. Attach the Compression Driver (7165-4517) to the T-Handle and insert the assembly through the Guide Bolt into the top of the nail until it contacts the most proximal 5.0mm locking screw. Turn the Compression Driver clockwise to drive the locking screw distally and compress the fracture up to 7mm.
2. Lock the nail distally, fully insert the dynamic locking screw as previously described and remove the Drill Guide/Anterior Drop assembly. Insert the Nail Cap Set Screw (7165-6000) into the top of the nail and advance with the Medium Hexdriver/T-Handle assembly until the fracture is compressed and the Nail Cap Set Screw has fully engaged the locking screw.

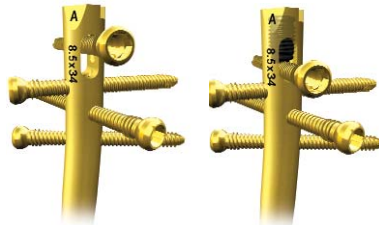

Distal Locking

Distal locking is typically approached from the medial side using a free hand technique. Confirm fracture reduction and align the C-Arm in either the AP or lateral position depending on which locking screw is to be inserted. Obtain a “perfect circle” image of the locking hole and use a blunt object to approximate the location of the locking hole by dimpling the skin.

Make a stab incision at the site, insert the 4.0mm Short Drill*, and drill both cortices. Measure for screw length using the Screw Depth Gauge. Alternatively, leave the 4.0mm Short Drill* in place, insert the Screw Length Sleeve down to bone, and read the exposed calibrations off the drill. Insert the appropriate length screw using the T-Handle/Hexdriver assembly.

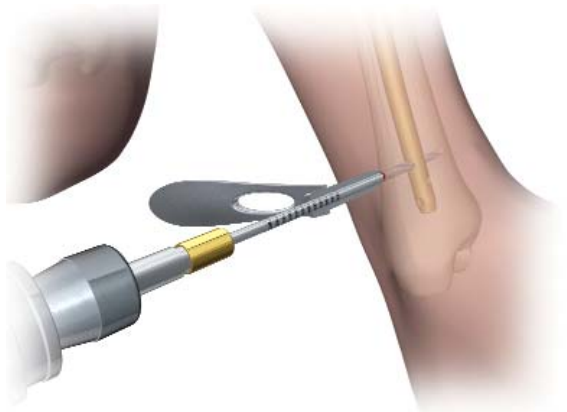

* 4.0mm Short Drill (7163-1117) is interchangeable with 4.0mm AO Short Drill (7163-1123)

Surgical Technique (continued)

Instruments for Blocking Screw Insertion



**Tibia Blocking
Screw Attachment**
Cat. No. 7165-4509



**11.0mm T-Handle
Awl**
Cat. No. 7165-4522



**8.5mm/10.0mm
Screw Cartridge**
Cat. No. 7165-4511



**11.5mm/13.0mm
Screw Cartridge**
Cat. No. 7165-4513



**Offset Blocking
Screw Cartridge**
Cat. No. 7165-4514



Blocking Screw Alignment Pin
Cat. No. 7165-4523



4.0mm Long Pilot Drill*
Cat. No. 7163-1110



4.0mm Drill Sleeve
Cat. No. 7167-4083



9.0mm Drill Sleeve
Cat. No. 7163-1152



Medium Hexdriver
Cat. No. 7163-1066



Mini Connector
Cat. No. 7163-1186



**Blocking Screw
Device**
Cat. No. 7165-4515



T-Handle
Cat. No. 7167-4076

* 4.0mm Long Pilot Drill (7163-1110) is interchangeable with 4.0mm AO Long Drill (7163-1121)

Blocking Screw Technique: Incision & Entry Point

A 2cm incision is made in-line with the intramedullary canal. This may be patellar splitting, medial or lateral parapatellar in its orientation.

The entry point is located just medial to the lateral tibial eminence in the AP view and in-line with the anterior cortex and intramedullary canal in the lateral.

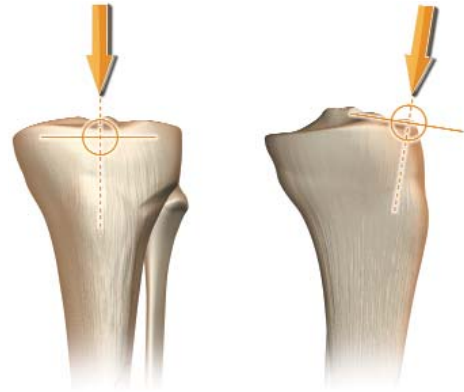

Entry Portal Acquisition

Insert the 11.0mm T-Handle Awl (7165-4522) manually to a depth just proximal to the fracture.

Note: When creating the initial entry point, pay close attention to the trajectory of the Awl and its relationship to the anatomic axis of the tibia. Correct Awl trajectory in the proximal fragment must be established prior to alignment with the anatomic axis of the distal fragment. This will ensure accurate fracture reduction when the nail is inserted.



Surgical Technique (continued)

AP Blocking Screw Insertion

In order to prevent varus or valgus malalignment of the proximal fragment, blocking screws may be placed in the AP plane. Attach the Blocking Screw Device (7165-4515) to the 11.0mm T-Handle Awl and move it into the desired position in the AP plane.



Note: The Blocking Screw Alignment Pins (7165-4523) can be screwed into the three (3) threaded holes on the metal handle of the Blocking Screw Device to serve as external points of reference during fracture alignment.

Tighten the device to the Awl and insert the appropriate Blocking Screw Cartridge (7165-4511, 7165-4513, 7165-4514). Adjust the Cartridge proximally or distally within the Blocking Screw Device to determine blocking screw position.

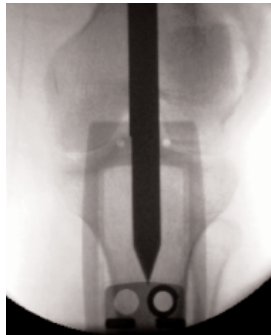

Insert the gold 9.0mm Drill Sleeve and silver 4.0mm Drill Sleeve into the desired cartridge hole and down to bone. Drill both cortices with the 4.0mm Long Pilot Drill*. Screw length is determined by reading the exposed drill bit calibrations or by removing the 4.0mm Drill Sleeve and measuring with the Screw Depth Gauge. Insert the screw with the Medium Hexdriver/T-Handle assembly until the screw engages the far cortex.



Note: Use caution during drilling and insertion of blocking screws in the AP plane. Plunging the drill bit past the posterior cortex or insertion of a screw that is too long may damage the neurovascular structures located posterior to the proximal tibia.

* 4.0mm Long Pilot Drill (7163-1110) is interchangeable with 4.0mm AO Long Drill (7163-1121)

Following implantation of the proximal blocking screw and fracture reduction, pass the 11.0mm T-Handle Awl into the distal fragment.

Re-position either the Blocking Screw Cartridge or the Awl as necessary and follow the previously described technique for blocking screw insertion.



ML Blocking Screw Insertion

In order to prevent anterior or posterior malalignment of the proximal fragment, blocking screws may also be placed in the ML plane. Attach the Blocking Screw Device to the 11.0mm T-Handle Awl and rotate it into the desired position in the ML plane.



Tighten the device to the Awl and insert the appropriate Blocking Screw Cartridge. Adjust the Cartridge proximally or distally within the Blocking Screw Device to determine blocking screw position. Blocking screw insertion follows the previously described technique.



Surgical Technique (continued)

Blocking Screw Insertion with Reducer

Blocking screw insertion can also be performed by attaching the Blocking Screw Device to the Reducer instead of the 11.0mm T-Handle Awl. Blocking screw insertion follows the previously described technique.



Final View: AP & ML Blocking Screw Insertion

Once blocking screw insertion is complete, remove the Blocking Screw Device from the 11.0mm T-Handle Awl or Reducer and obtain both AP and lateral radiographic images to confirm accurate placement.

The Awl or Reducer provides a good indication of the nail's insertion trajectory based upon the location of the blocking screws. Following confirmation of proper screw placement, proceed with nail insertion following the META-NAIL[®] Tibial Nail insertion technique.

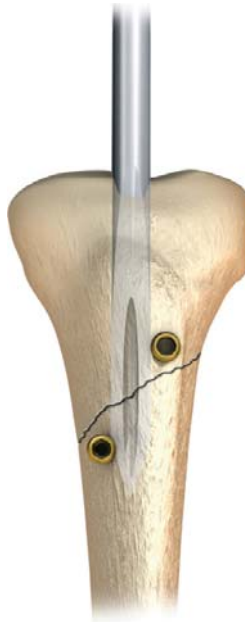

Stability Locking Screw Insertion

Following nail insertion and confirmation of fracture reduction, blocking screws can be placed on either side of the nail in the metaphyseal region for additional stability. Screws may be inserted in both the AP and ML planes.

With the nail inserted, attach the Tibia Blocking Screw Attachment (7165-4509) to the Anterior Drop (Triangle to Triangle for AP screws and Square to Square for ML screws). Follow the previously described technique for Cartridge positioning and blocking screw insertion.

Note: The AP blocking screws targeted through the two (2) holes built into the Anterior Drop cannot be used if the most inferior oblique proximal locking screw has been inserted.



Surgical Technique (continued)

Final View: Stability Blocking Screws

Once stability blocking screw insertion is complete, remove the Blocking Screw Attachment and Anterior Drop from the Drill Guide and obtain both AP and lateral radiographic images to confirm accurate placement.



TRIGEN[®] Nail Cap Insertion: Optional

Remove the Drill Guide/Anterior Drop assembly. Attach the selected Nail Cap to the Medium Hexdriver/T-Handle assembly and insert into the top of the nail until tight.

A Nail Cap cannot be used if a Nail Cap Set Screw is implanted or if a locking screw is inserted in the dynamic locking position. The tip of the Nail Cap will contact the locking screw and prevent complete engagement of the Nail Cap with the nail.



Note: If cross-threading occurs, rotate the Nail Cap counterclockwise until its threads line up with those of the nail. Proceed with insertion until tight.

Instruments for Implant Removal



3.2mm Tip Threaded Guide Wire
Cat. No. 7163-1690



Mini Connector
Cat. No. 7163-1186



12.5mm Entry Reamer
Cat. No. 7163-1116



Disposable Nail Extractor***
Cat. No. 7163-1320



Impactor
Cat. No. 7167-4081



One Piece Impactor**
Cat. No. 7163-1185



3.0mm x 1000mm Ball Tip Guide Rod*
Cat. No. 7163-1626



Slotted Hammer
Cat. No. 7167-4082

* Additional Guide Rods listed on page 31

** The One Piece Impactor is located in the original TRIGEN® Instrument Set (7163-1326)

*** The Disposable Nail Extractor (7163-1320) is interchangeable with the Large Nail Extractor (7163-1278) located in the original TRIGEN Instrument Set (7163-1326) and the HFN® Instrument Set (7170-0001)

Surgical Technique (continued)

Nail Extraction: Optional

Standard Technique

Remove the Nail Cap or Nail Cap Set Screw if implanted and all of the distal locking screws with the Medium Hexdriver/T-Handle assembly. Remove all of the proximal locking screws except for one in the same manner.

Thread the Impactor (7167-4081) or One Piece Impactor (7163-1185)* into the back of the Disposable Nail Extractor (7163-1320)** and then thread the assembly into the top of the nail. Remove the remaining proximal locking screw and then extract the nail with a back-slapping motion using the Slotted Hammer.

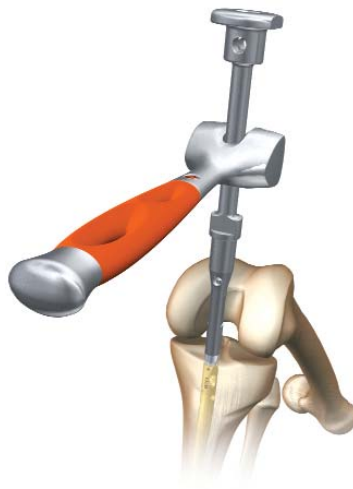

Percutaneous Technique

This technique assumes the absence of a Nail Cap or Nail Cap Set Screw. Remove all distal locking screws and all but one of the proximal locking screws as previously described. Under fluoroscopy, insert a 3.2mm Tip Threaded Guide Wire into the top of the nail on power or by hand. Make a 2cm incision around the pin and advance the 12.5mm Entry Reamer over the pin and into the top of the nail to remove any bony in-growth.

Thread the Impactor or One Piece Impactor* into the back of the Disposable Nail Extractor** and then thread the assembly into the top of the nail. Remove the remaining proximal locking screw and then extract the nail with a back-slapping motion.



Note: The tip of the Entry Reamer is straight for approximately 1cm before flaring out. It is this portion of the Entry Reamer that enters the top of the nail.

* The One Piece Impactor is located in the original TRIGEN® Instrument Set (7163-1326)

** The Disposable Nail Extractor (7163-1320) is interchangeable with the Large Nail Extractor located in the original TRIGEN Instrument Set (7163-1326) and the HFN(tm) Instrument Set (7170-0001)

An Alternative Method for Extraction

Guide Rod Jamming Technique

Advance the end of a 3.0mm Ball Tip Guide Rod through the end of the nail. Insert a 2.0mm Smooth Guide Rod (7111-8280) in the same manner. With both Guide Rods in place attach the Gripper to the end of the 3.0mm Ball Tip Guide Rod and pull it back so that it wedges the ball tip against the 2.0mm Smooth Guide Rod. Backslap against the Gripper with the Slotted Hammer to extract the nail.

Guide Rods

Cat. No.	Description
7111-8280	2.0mm x 900mm Smooth (RUSSELL-TAYLOR [°] System)*
7111-8202	3.0mm x 900mm Ball Tip (RUSSELL-TAYLOR System)*
7163-1626	3.0mm x 1000mm Ball Tip (TRIGEN [°] System)

Additional Removal Items

Cat. No.	Description
115074	Large Extractor Hook*
115073	Small Extractor Hook*
914658	Large Easy Out**
914659	Small Easy Out**

* Available sterile packed. For nail removal only, do not use for nail insertion

** Located in RUSSELL-TAYLOR Extraction Kit (Set #7508) available through Loaners

Catalog Information – Implants

TRIGEN® Internal Captured Screws

4.5mm and 5.0mm

Set No. 7163-1321

Cat. No.	Length
7164-2125	Internal Hex Captured Screw 4.5mm X 25mm
7164-2130	Internal Hex Captured Screw 4.5mm X 30mm
7164-2135	Internal Hex Captured Screw 4.5mm X 35mm
7164-2140	Internal Hex Captured Screw 4.5mm X 40mm
7164-2145	Internal Hex Captured Screw 4.5mm X 45mm
7164-2150	Internal Hex Captured Screw 4.5mm X 50mm
7164-2225	Internal Hex Captured Screw 5.0mm X 25mm
7164-2230	Internal Hex Captured Screw 5.0mm X 30mm
7164-2235	Internal Hex Captured Screw 5.0mm X 35mm
7164-2240	Internal Hex Captured Screw 5.0mm X 40mm
7164-2245	Internal Hex Captured Screw 5.0mm X 45mm
7164-2250	Internal Hex Captured Screw 5.0mm X 50mm
7164-2255	Internal Hex Captured Screw 5.0mm X 55mm
7164-2260	Internal Hex Captured Screw 5.0mm X 60mm
7164-2265	Internal Hex Captured Screw 5.0mm X 65mm
7164-2270	Internal Hex Captured Screw 5.0mm X 70mm
7164-2275	Internal Hex Captured Screw 5.0mm X 75mm



TRIGEN META-NAIL® 8.5mm Tibial

Set No. 7165-3002

Cat. No.	Length	Availability
7165-5016*	META-NAIL Tibial 8.5mm x 16cm	Outlier
7165-5018*	META-NAIL Tibial 8.5mm x 18cm	Outlier
7165-5020*	META-NAIL Tibial 8.5mm x 20cm	Outlier
7165-5022*	META-NAIL Tibial 8.5mm x 22cm	Outlier
7165-5024	META-NAIL Tibial 8.5mm x 24cm	Implant set
7165-5026	META-NAIL Tibial 8.5mm x 26cm	Implant set
7165-5028	META-NAIL Tibial 8.5mm x 28cm	Implant set
7165-5029	META-NAIL Tibial 8.5mm x 29cm	Outlier
7165-5030	META-NAIL Tibial 8.5mm x 30cm	Implant set
7165-5031	META-NAIL Tibial 8.5mm x 31cm	Outlier
7165-5032	META-NAIL Tibial 8.5mm x 32cm	Implant set
7165-5033	META-NAIL Tibial 8.5mm x 33cm	Implant set
7165-5034	META-NAIL Tibial 8.5mm x 34cm	Implant set
7165-5035	META-NAIL Tibial 8.5mm x 35cm	Implant set
7165-5036	META-NAIL Tibial 8.5mm x 36cm	Implant set
7165-5037	META-NAIL Tibial 8.5mm x 37cm	Implant set
7165-5038	META-NAIL Tibial 8.5mm x 38cm	Implant set
7165-5039	META-NAIL Tibial 8.5mm x 39cm	Outlier
7165-5040	META-NAIL Tibial 8.5mm x 40cm	Outlier
7165-5041	META-NAIL Tibial 8.5mm x 41cm	Outlier
7165-5042	META-NAIL Tibial 8.5mm x 42cm	Outlier
7165-5043*	META-NAIL Tibial 8.5mm x 43cm	Outlier
7165-5044*	META-NAIL Tibial 8.5mm x 44cm	Outlier
7165-5046	META-NAIL Tibial 8.5mm x 46cm	Outlier
7165-5048	META-NAIL Tibial 8.5mm x 48cm	Outlier
7165-5050	META-NAIL Tibial 8.5mm x 50cm	Outlier



* Available through special order

TRIGEN[®] META-NAIL[®] 10mm Tibial

Set No. 7165-3000

Cat. No.	Length	Availability
7165-5116*	META-NAIL Tibial 10mm x 16cm	Outlier
7165-5118*	META-NAIL Tibial 10mm x 18cm	Outlier
7165-5120*	META-NAIL Tibial 10mm x 20cm	Outlier
7165-5122*	META-NAIL Tibial 10mm x 22cm	Outlier
7165-5124*	META-NAIL Tibial 10mm x 24cm	Outlier
7165-5126	META-NAIL Tibial 10mm x 26cm	Outlier
7165-5128	META-NAIL Tibial 10mm x 28cm	Implant set
7165-5129	META-NAIL Tibial 10mm x 29cm	Outlier
7165-5130	META-NAIL Tibial 10mm x 30cm	Implant set
7165-5131	META-NAIL Tibial 10mm x 31cm	Outlier
7165-5132	META-NAIL Tibial 10mm x 32cm	Implant set
7165-5133	META-NAIL Tibial 10mm x 33cm	Outlier
7165-5134	META-NAIL Tibial 10mm x 34cm	Implant set
7165-5135	META-NAIL Tibial 10mm x 35cm	Implant set
7165-5136	META-NAIL Tibial 10mm x 36cm	Implant set
7165-5137	META-NAIL Tibial 10mm x 37cm	Implant set
7165-5138	META-NAIL Tibial 10mm x 38cm	Implant set
7165-5139	META-NAIL Tibial 10mm x 39cm	Implant set
7165-5140	META-NAIL Tibial 10mm x 40cm	Implant set
7165-5141	META-NAIL Tibial 10mm x 41cm	Outlier
7165-5142	META-NAIL Tibial 10mm x 42cm	Outlier
7165-5143	META-NAIL Tibial 10mm x 43cm	Outlier
7165-5144	META-NAIL Tibial 10mm x 44cm	Outlier
7165-5146*	META-NAIL Tibial 10mm x 46cm	Outlier
7165-5148*	META-NAIL Tibial 10mm x 48cm	Outlier
7165-5150*	META-NAIL Tibial 10mm x 50cm	Outlier



* Available through special order

Catalog Information – Implants (continued)

TRIGEN[®] META-NAIL[®] 11.5mm Tibial

Set No. 7165-3001

Cat. No.	Length	Availability
7165-5216*	META-NAIL Tibial 11.5mm x 16cm	Outlier
7165-5218*	META-NAIL Tibial 11.5mm x 18cm	Outlier
7165-5220*	META-NAIL Tibial 11.5mm x 20cm	Outlier
7165-5222*	META-NAIL Tibial 11.5mm x 22cm	Outlier
7165-5224*	META-NAIL Tibial 11.5mm x 24cm	Outlier
7165-5226	META-NAIL Tibial 11.5mm x 26cm	Outlier
7165-5228	META-NAIL Tibial 11.5mm x 28cm	Outlier
7165-5229	META-NAIL Tibial 11.5mm x 29cm	Outlier
7165-5230	META-NAIL Tibial 11.5mm x 30cm	Implant set
7165-5231	META-NAIL Tibial 11.5mm x 31cm	Outlier
7165-5232	META-NAIL Tibial 11.5mm x 32cm	Implant set
7165-5233	META-NAIL Tibial 11.5mm x 33cm	Outlier
7165-5234	META-NAIL Tibial 11.5mm x 34cm	Implant set
7165-5235	META-NAIL Tibial 11.5mm x 35cm	Implant set
7165-5236	META-NAIL Tibial 11.5mm x 36cm	Implant set
7165-5237	META-NAIL Tibial 11.5mm x 37cm	Implant set
7165-5238	META-NAIL Tibial 11.5mm x 38cm	Implant set
7165-5239	META-NAIL Tibial 11.5mm x 39cm	Implant set
7165-5240	META-NAIL Tibial 11.5mm x 40cm	Implant set
7165-5241	META-NAIL Tibial 11.5mm x 41cm	Outlier
7165-5242	META-NAIL Tibial 11.5mm x 42cm	Outlier
7165-5243	META-NAIL Tibial 11.5mm x 43cm	Outlier
7165-5244	META-NAIL Tibial 11.5mm x 44cm	Outlier
7165-5246*	META-NAIL Tibial 11.5mm x 46cm	Outlier
7165-5248*	META-NAIL Tibial 11.5mm x 48cm	Outlier
7165-5250*	META-NAIL Tibial 11.5mm x 50cm	Outlier



* Available through special order

TRIGEN[®] META-NAIL[®] 13mm Tibial

Cat. No.	Length	Availability
7165-5316*	META-NAIL Tibial 13mm x 16cm	Outlier
7165-5318*	META-NAIL Tibial 13mm x 18cm	Outlier
7165-5320*	META-NAIL Tibial 13mm x 20cm	Outlier
7165-5322*	META-NAIL Tibial 13mm x 22cm	Outlier
7165-5324*	META-NAIL Tibial 13mm x 24cm	Outlier
7165-5326*	META-NAIL Tibial 13mm x 26cm	Outlier
7165-5328*	META-NAIL Tibial 13mm x 28cm	Outlier
7165-5329*	META-NAIL Tibial 13mm x 29cm	Outlier
7165-5330	META-NAIL Tibial 13mm x 30cm	Outlier
7165-5331	META-NAIL Tibial 13mm x 31cm	Outlier
7165-5332	META-NAIL Tibial 13mm x 32cm	Outlier
7165-5333	META-NAIL Tibial 13mm x 33cm	Outlier
7165-5334	META-NAIL Tibial 13mm x 34cm	Outlier
7165-5335	META-NAIL Tibial 13mm x 35cm	Outlier
7165-5336	META-NAIL Tibial 13mm x 36cm	Outlier
7165-5337	META-NAIL Tibial 13mm x 37cm	Outlier
7165-5338	META-NAIL Tibial 13mm x 38cm	Outlier
7165-5339	META-NAIL Tibial 13mm x 39cm	Outlier
7165-5340	META-NAIL Tibial 13mm x 40cm	Outlier
7165-5341	META-NAIL Tibial 13mm x 41cm	Outlier
7165-5342	META-NAIL Tibial 13mm x 42cm	Outlier
7165-5343	META-NAIL Tibial 13mm x 43cm	Outlier
7165-5344	META-NAIL Tibial 13mm x 44cm	Outlier
7165-5346*	META-NAIL Tibial 13mm x 46cm	Outlier
7165-5348*	META-NAIL Tibial 13mm x 48cm	Outlier
7165-5350*	META-NAIL Tibial 13mm x 50cm	Outlier



Nail Cap Set Screw

Cat. No. 7165-6000



TRIGEN Nail Caps

Cat. No.	Length
7163-4000	0mm
7163-4005	5mm
7163-4010	10mm
7163-4015	15mm
7163-4020	20mm



* Available through special order

Catalog Information – Instruments

TRIGEN[®] META-NAIL[®] Blocking Screw Instruments

Set No. 7165-4001

Blocking Screw Device

Cat. No. 7165-4515



Tibia Blocking Screw Attachment

Cat. No. 7165-4509



11.0mm T-Handle Awl

Cat. No. 7165-4522



8.5mm/10mm Blocking Screw Cartridge

Cat. No. 7165-4511



11.5mm/13mm Blocking Screw Cartridge

Cat. No. 7165-4513



Offset Blocking Screw Cartridge

Cat. No. 7165-4514



Blocking Screw Alignment Pin

Cat. No. 7165-4523



Retrograde Femoral Blocking Screw Attachment*

Cat. No. 7165-4508



Blocking Screw Instrument Case

Cat. No. 7165-4552

Blocking Screw Instrument Lid

Cat. No. 7165-4553



* Not used in META-NAIL tibial technique

TRIGEN[®] META-NAIL[®] Instruments

Set No. 7165-4002

META-NAIL Anterior Drop

Cat. No. 7165-4501



META-NAIL Drill Guide

Cat. No. 7165-4502



META-NAIL Extension Drill Guide

Cat. No. 7165-4503



Extension Guide Bolt (23mm)

Cat. No. 7165-4505



Guide Bolt Long (51mm)

Cat. No. 7165-4506



META-NAIL Instrument Case

Cat. No. 7165-4551



META-NAIL Instrument Lid

Cat. No. 7165-4550

Long Screw Length Sleeve

Cat. No. 7165-4520



Short Impactor

Cat. No. 7165-4521



Catalog Information – Instruments (continued)

Instruments used if you have TRIGEN[®] Base

Set No. 7167-4012

Medium Hexdriver

Cat. No. 7163-1066



Short Hexdriver

Cat. No. 7163-1068



12.5mm Entry Reamer

Cat. No. 7163-1116



Guide Bolt Wrench

Cat. No. 7163-1140



9.0mm Drill Sleeve

Cat. No. 7163-1152



Multipurpose Driver

Cat. No. 7163-1161



Mini Connector

Cat. No. 7163-1186



Screw Depth Gauge

Cat. No. 7163-1189



Cannulated Awl

Cat. No. 7167-4000



Entry Portal Tube

Cat. No. 7167-4060



3.2mm T-Handle Trocar

Cat. No. 7167-4074



Honeycomb

Cat. No. 7167-4075



Flexible Reamer Shaft

Cat. No. 7111-8200



Reamer Heads

Cat. No. 7111-8231-8246



T-Handle

Cat. No. 7167-4076



Reducer

Cat. No. 7167-4077



Obturator

Cat. No. 7167-4078



Ruler

Cat. No. 7167-4079



Gripper

Cat. No. 7167-4080



Impactor

Cat. No. 7167-4081



Slotted Hammer

Cat. No. 7167-4082



4.0mm Drill Sleeve

Cat. No. 7167-4083



Screwdriver Release

Cat. No. 7167-4084



Screw Length Sleeve

Cat. No. 7167-4085



Entry Portal Handle

Cat. No. 7167-4092



Catalog Information – Instruments (continued)

Instruments used if you have existing TRIGEN[®] set

Set No. 7163-1326

Medium Hexdriver

Cat. No. 7163-1066



Short Hexdriver

Cat. No. 7163-1068



Gripper

Cat. No. 7163-1100



Entry Tool

Cat. No. 7163-1114



12.5mm Entry Reamer

Cat. No. 7163-1116



Obturator

Cat. No. 7163-1122



Reducer

Cat. No. 7163-1124



Ruler

Cat. No. 7163-1128



Guide Bolt Wrench

Cat. No. 7163-1140



Hammer

Cat. No. 7163-1150



9.0mm Drill Sleeve

Cat. No. 7163-1152



4.0mm Drill Sleeve

Cat. No. 7163-1156



Multipurpose Driver

Cat. No. 7163-1161



T-Handle

Cat. No. 7163-1172



Mini Connector

Cat. No. 7163-1186



Screw Depth Gauge

Cat. No. 7163-1189



Screw Driver Release Handle

Cat. No. 7163-1208



One Piece Impactor

Cat. No. 7163-1185



Flexible Reamer Shaft

Cat. No. 7163-1192



Reamer Heads

Cat. No. 7111-8231-8242



META-NAIL[®] Disposables

Set No. 7165-4003

4.0mm Long Pilot Drill*

Cat. No. 7163-1110



4.0mm Short Drill**

Cat. No. 7163-1117



3.0mm x 1000mm Ball Tip Guide Rod

Cat. No. 7163-1626



3.2mm Tip Threaded Guide Wire

Cat. No. 7163-1690



TRIGEN[®] META-NAIL Disposable

Compression Driver

Cat. No. 7165-4517



Disposable Nail Extractor***

Cat. No. 7163-1320



* 4.0mm Long Pilot Drill (7163-1110) is interchangeable with 4.0mm AO Long Drill (7163-1121)

** 4.0mm Short Drill (7163-1117) is interchangeable with 4.0mm AO Short Drill (7163-1123)

*** The Disposable Nail Extractor (7163-1320) is interchangeable with the Large Nail Extractor (7163-1278) located in the original TRIGEN Instrument Set (7163-1326) and the HFN[®] Instrument Set (7170-0001)

**Orthopaedic Trauma &
Clinical Therapies**

Smith & Nephew, Inc.
1450 Brooks Road
Memphis, TN 38116
USA

www.smith-nephew.com

Telephone: 1-901-396-2121
Information: 1-800-821-5700
Orders/Inquiries: 1-800-238-7538